



Surge Protective Device

Paperless Datasheet

Going green and protecting environment is manufacturers' responsibility. Each WatchfulEyE product has a link of downloading data sheet on its enclosure:
<http://datasheet.watchfuleyesolutions.com/US120287.html>

Model & Ordering Code

Model	Ordering Code	Remote Contacts	UPC/EAN Code	
WTH-500/G+/R/1P-320	US120287	YES	(0) 811914031093	
WTH-500/G+/1P-320	US120284	NO	(0) 811914031123	

Model with suffix	WTH-500/G+/R/1P-320	x2pcs	x3pcs	x4pcs
Ordering Code	US120287	US120287x2	US120287x3	US120287x4

Model with suffix	WTH-500/G+/1P-320	x2pcs	x3pcs	x4pcs
Ordering Code	US120284	US120284x2	US120284x3	US120284x4



Certificates of Products

CE RoHS IEC61643-11



Surge Protective Device

Description

In accordance with: IEC 61643-11 - Class I and UL1449 Type 4 Location

Location of use: main sub-distribution boards

Built-in 7-layer High Energy GDT: Safely applied to L-PE mode to realize Class I surge protection.

WTH-500/G+/R/1P-320 Series Technical Data

Maximum Continuous Operating Voltage (Uc/MCOV)	320VAC 50/60Hz
Dc spark-over voltage at 100 V/s	>500V
Requirement Class to IEC61643-11	Class I
IEEE Category Rating	C & B
Nominal Discharge Current (In)	200kA
Max. Discharge Current (Imax)	400kA
Pulsed Current (Iimp)	50kA
Residual Voltage (Ures @6kV/3kA)	1.7kV
Protection Modes	L-PE, N-PE
Protective Element	7-layer High Energy GDT
Follow Current (If)	3kA rms (at 320V) / 5kA rms (at 255V)
Response Time (tA)	<100ns
Leakage Current (at 75%U1mA)	None
Fault Indication	None
Protection Rating (IP Code)	IP 20
Short Circuit Current Ratings (SCCR)	25kA rms
Max. Back-up Fuse (if mains >315A)	315A gL (circuit-breaker: <160A)
Surge Life at 3kA (8/20µs)	>5000 events
Temperature Range	- 40°F to 176°F (-40°C to 80°C)
Relative Humidity	0% to 95% noncondensing
Maximum Operating Altitude	10,000 feet (3000m)
Terminal Cross Section	35mm ² (solid) / 25mm ² (stranded)
Stripping Length Contacts	0.6inches (15mm)
Terminal Screw Torque	Max. 3.5Nm
DIN Rail EN60715	35mm top-hat rail
Dimensions DIN 43880	36mm (2TE)
Housing Material	Thermoplastic (UL94 V-0)
Housing Design	Compact design
Net Weight Per Unit	0.57Lb (259g)

Surge Protection Connection Diagram

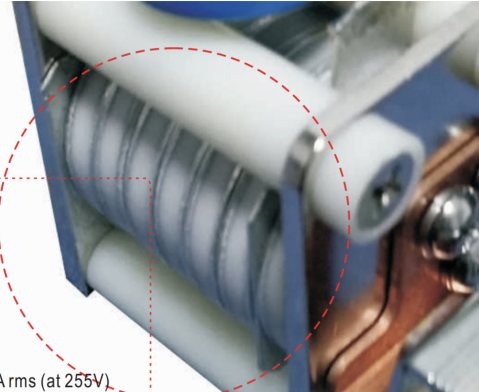
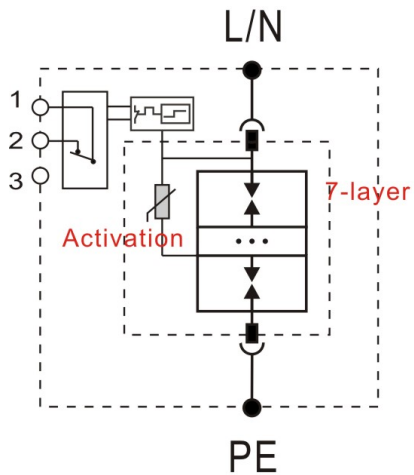

Built-in 7-layer High Energy GDT

★ Follow Current (I_f):
3kArms (at 320V) / 5kArms (at 255V)

Safely applied to L-PE mode to realize Class I surge protection

Activation: improve the sensitivity of anti surge, activate surge protection under lower voltage

Dimensions

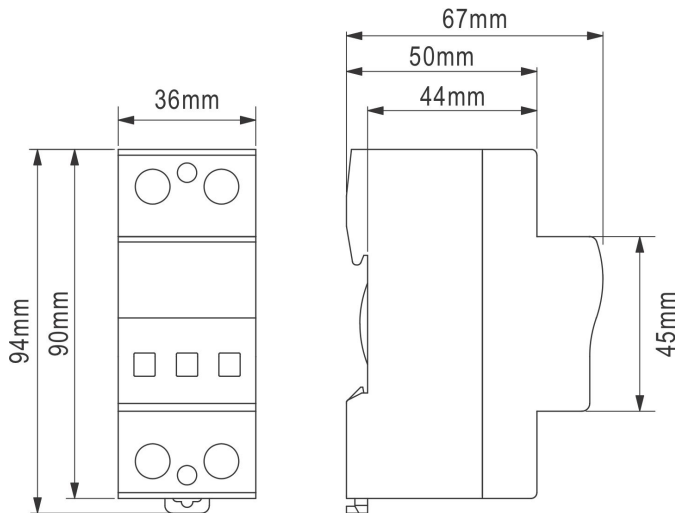

Remote Contacts

- 1: COM (Common)
- 2: NC (Normally Close)



Remote Contacts

Contact Ratings	125VAC/3A, 250VAC/1.5A
Terminal Cross Section	Max. 1.5mm ²
Stripping Length Contacts	0.25 inches (6-7mm)
Remote Terminal Torque	0.25Nm

Common Terms and Definitions

1. Normal operating voltage rating (U_n)
2. Maximum Continuous Operating Voltage (U_c /MCOV):
Maximum r.m.s. voltage, which may be continuously applied to the surge protective device's mode of protection.
3. Nominal Discharge Current for Class II Test (I_n):
crest value of the current through the surge protective device having a current waveshape of $8/20\mu s$.
4. Maximum Discharge Current (I_{max}):
Crest value of a current through the surge protective device having an $8/20\mu s$ waveshape and magnitude according to the manufacturers specification. I_{max} is equal to or greater than I_n .
5. Voltage Protection Level (U_p):
Maximum voltage to be expected at the surge protective device terminals due to an impulse stress with defined voltage steepness and an impulse stress with a discharge current with given amplitude and waveshape.
6. Residual Voltage (U_{res}):
Crest value of voltage that appears between the terminals of an surge protective device due to the passage of discharge current.
7. IEEE 62.41
CATEGORY C: outdoor overhead lines, service entrance (most severe)
CATEGORY B: major feeder, short branch circuits, service panel (indoor)
CATEGORY A: long branch circuits, receptacles (indoor) (least severe)

How to choose a suitable U_c (MCOV) value

Note: $U_c > 1.15U_n$

The relationship between two parameters U_c and U_p of a surge protective device is proportional.

If U_c is small, the value of U_p is also small; surge protective devices with smaller U_p can provide better surge protection. Whether to choose smaller U_c depends on the voltage stability of the grid.

If you choose surge protective devices with smaller U_c for the grid with instable voltage, the surge protective devices will frequently work while the grid voltage fluctuates, resulting in shortening surge protective device's product life.

If you choose larger U_c , and the value of U_p is accordingly large, the surge protective efficiency will not be so fine.

If you are unsure of the voltage stability of the grid,

it is suggested to calculate MCOV(U_c) using the following formula: $\sqrt{2} U_n < U_c < \sqrt{3} U_n$

AC Network (U_n)	MCOV(U_c), L/N-PE Protection Mode
110V	150V
120/208V	150V
127/220V	150V
220/380V	275V, 320V, 385V
230/400V	275V, 320V, 385V, 420V
240/415V	320V, 385V, 420V
277/480V	320V, 385V, 420V
347/600V	550V, 690V

AC Network Connection Diagram (1/2)

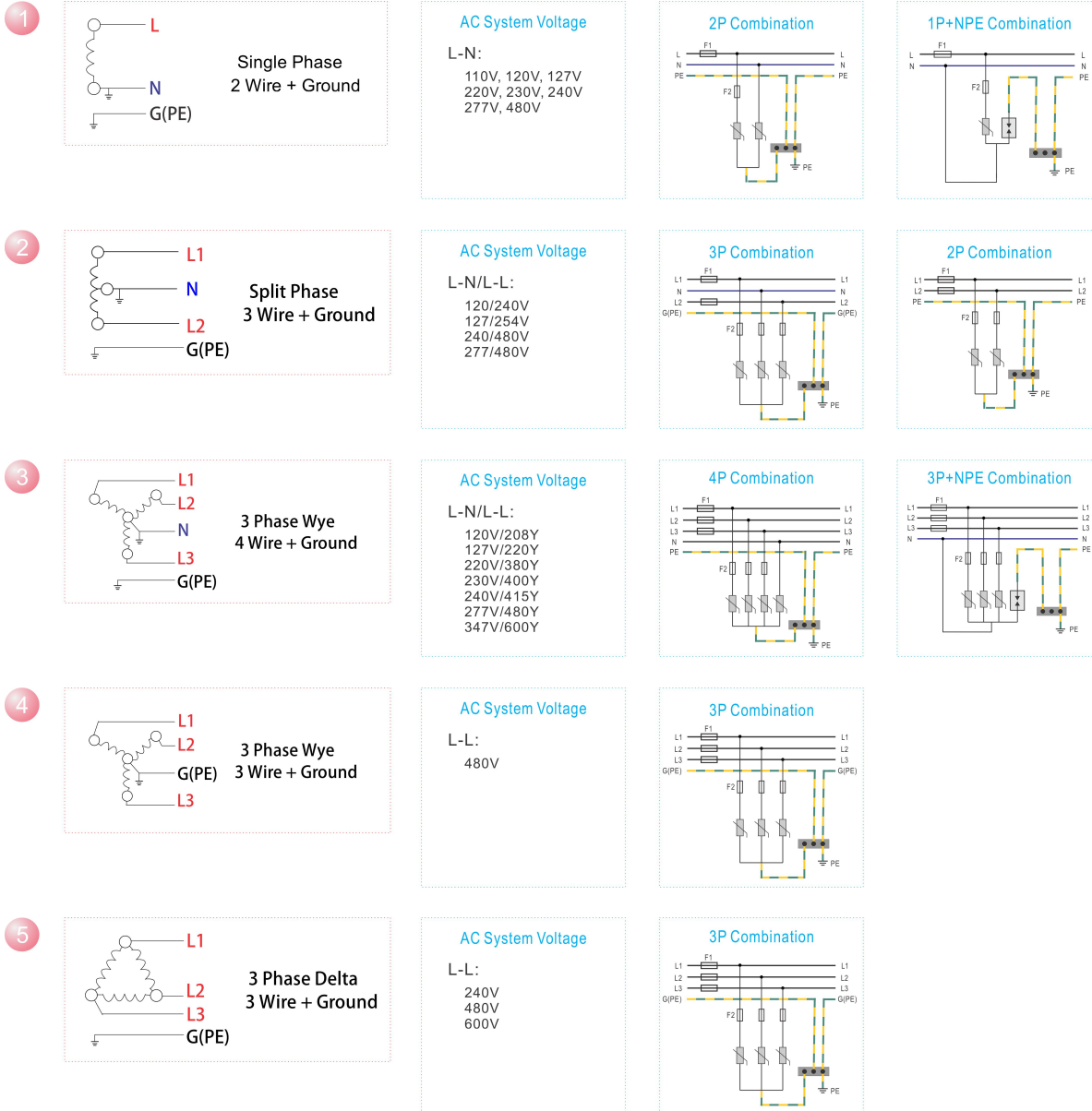

AC Network Connection Diagram (2/2)

6

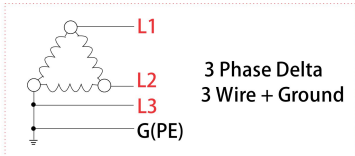

AC System Voltage

L-L:
240V
480V
600V

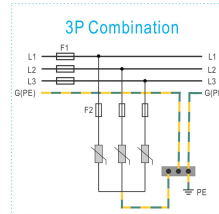

7

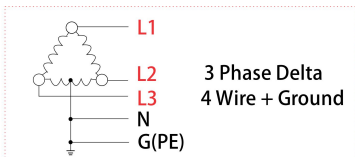

AC System Voltage

L-N/L-L:
120/240V
240/480V

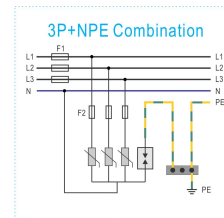
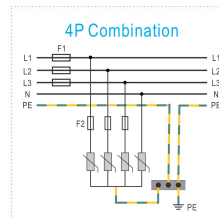

Difference mode & Common mode Connection Diagram

8

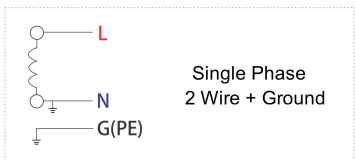

AC System Voltage

L-N:
110V, 120V, 127V
220V, 230V, 240V
277V, 480V

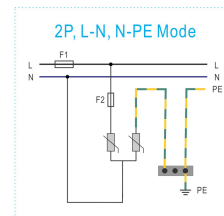
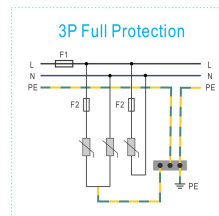

Common mode: L-PE, N-PE surge protection

Difference mode: L-N surge protection

Selection of back-up fuse

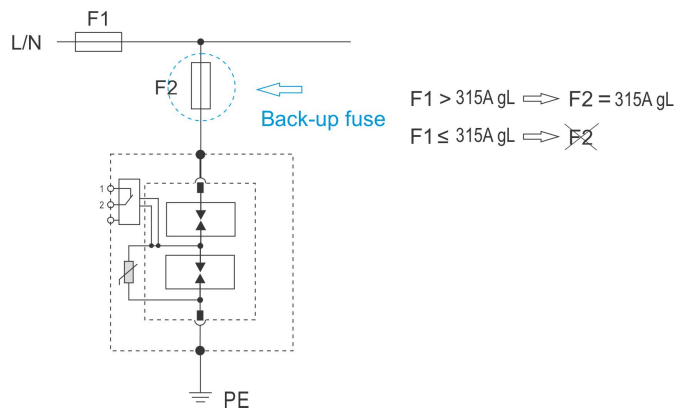

Selection of back-up circuit-breaker

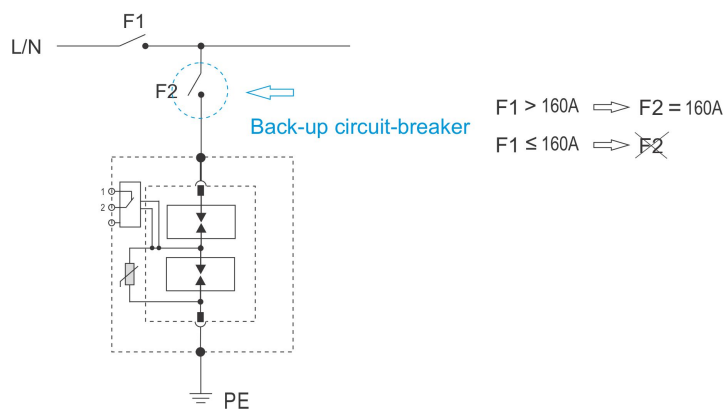

Application

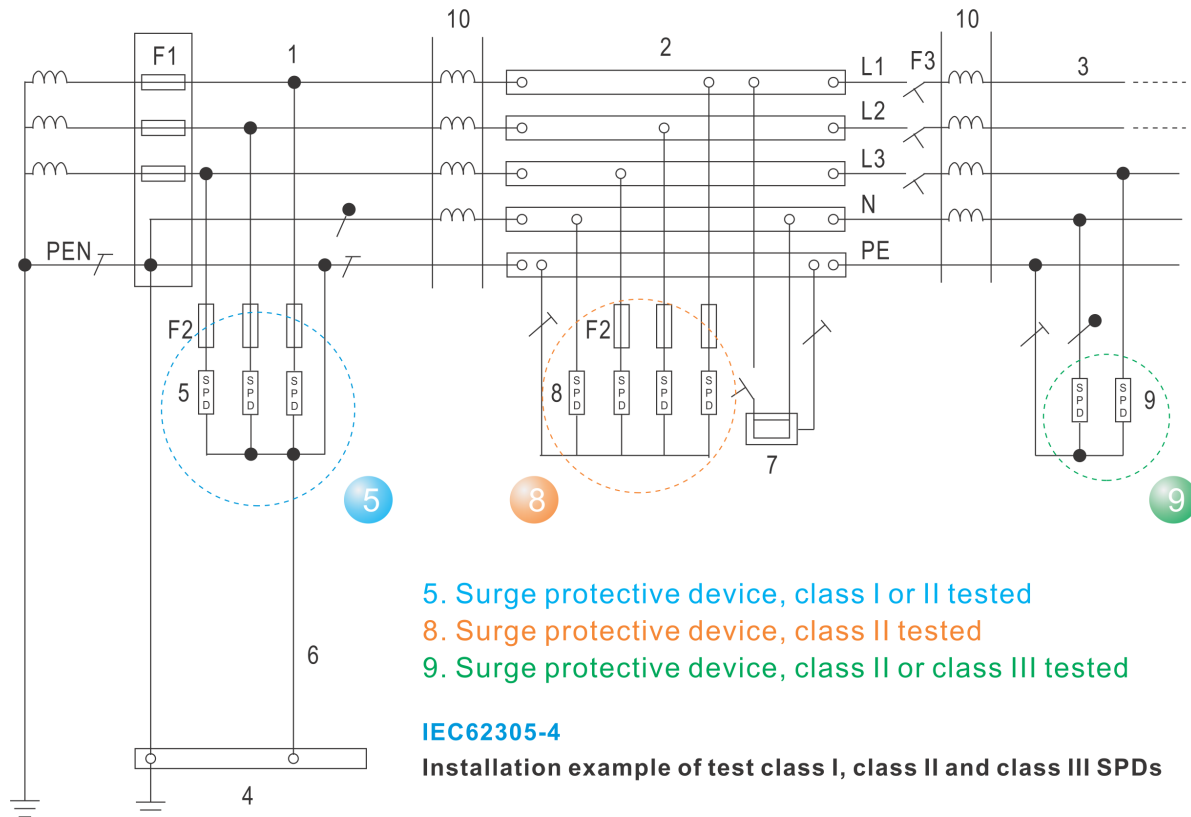

Key

1. Origin of the installation
 2. Distribution board
 3. Distribution outlet
 4. Main earthing terminal or bar
 5. Surge protective device, class I or II tested
 6. Earthing connection (earthing conductor) of the surge protective device
 7. Fixed equipment to be protected
 8. Surge protective device, class II tested
 9. Surge protective device, class II or class III tested
 10. Decoupling element or line length
- F1, F2, F3 overcurrent protective disconnectors
 NOTE Refer to IEC 61643-12 for further information.



Surge Protective Device

FAQ & Help

1. What should I do if I can't find the paper manual in the product packaging?

Watchful Eye products is committed to going green with paperless data sheets. On the side of each product enclosure is an engraved link with URL for downloading paperless data sheet and QR code of the website. If you need the paper data sheet, you can open the link and print the data sheet by yourself.

2. What instruments can be used to test whether its surge protection function is normal or not?

Test with a Watchful Eye surge protector tester

3. Can you list more applications?

Power supply panel, whole house



Surge Protective Device

Download WatchfulEye Official App

To learn about more products and updates from company, please scan QR code to download the official App:



After-sale Services

Watchful Eye provides a 5-year quality warranty globally.

[I have a question](#)